

# Voyager Style

# THORN

## 96631609 VOYAGER STYLE 150 MS E3T-S SM-S WH

$T_a$ -5 +30	IP43	IK03	CE	$T_a$ 0 +35
-----------------	------	------	----	----------------

### Voyager Style

Ultra slim LED escape sign luminaire for surface mounted, wall or ceiling mounting; recessed ceiling mounting possible with optional recessed ceiling frame; ; housing made of polycarbonate ; luminaire easy to install; Quick fit terminal block, through wiring possible up to 2,5 mm<sup>2</sup>; supplied with a set of ISO 7010 mountable direction signs (left, right, up, down and blank) for viewing from a maximum distance of 30 m; mounting of signs with discrete mounting pins; zero maintenance thanks to LED technology; service life of 50,000 h at constant luminous flux; uniform backlighting of pictogram; luminance > 500 cd/m<sup>2</sup> in the white region; Power supply: 220/240 V AC; Luminaire input power: 7.2 W; degree of protection: IP43, class of protection: Class II electrical (this product is not earthed); Impact strength: Impact strength: IK03; Dimensions: 341 x 37 x 230 mm; weight: 1.08 kg

Self-contained emergency luminaires rely on long-lasting batteries. Thorn batteries are robust and comes with a three-year guarantee (applicable subject to the terms and conditions of and to the extent as set forth in the manufacturer's guarantee on Thorn products, which shall be applicable analogously and which is available under [http://www.thornlighting.com/en/products/5-year-guarantee/5-year-warranty/terms-of-guarantee\\_en.pdf](http://www.thornlighting.com/en/products/5-year-guarantee/5-year-warranty/terms-of-guarantee_en.pdf). The battery guarantee shall not come into effect if the product has been installed later than three(3) months after delivery EXW (Incoterms 2010).



TLG\_VYST\_F\_150MS\_RT.jpg

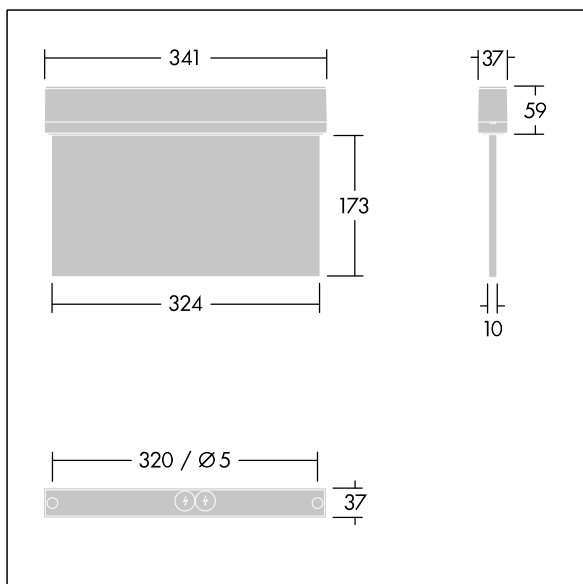

TLG\_VYST\_M\_150MS.wmf

All values marked with an \* are rated values. Unless stated otherwise, the values apply to an ambient temperature of 25°C.

Thorn Lighting is constantly developing and improving its products. The right is reserved to change specifications without prior notification or public announcement.  
© Thorn Lighting