

member of zumtobel group

THORN



Tonic Gyro & Gimbal

A global spotlight range offering full flexibility

Gyro



The global Tonic range now includes a gyro version, bringing the right lighting to retail applications and projects where a high flexibility is needed.

Tonic Gyro helps designers to create consistent interiors. Sharing its classic tubular look with the other luminaires in Thorn's Tonic range, its recessed gyro-mounting also keeps ceilings uncluttered.

A colour-rendering index (CRI) of over 90 makes Tonic Gyro ideal for retail applications where the quality of light plays an important role. Meanwhile, interchangeable lenses offer a variety of beam shapes, giving designers and customers maximum flexibility. Tonic Gyro is available in single, double and triple versions, with lumen packages of 1800 lm and 2 800 lm and colour temperatures of 3 000 K and 4 000 K.

Like the other products in the Tonic family, it's supplied with an integrated multi-voltage driver and therefore ready to be specified anywhere in the world.

Gimbal



Our new gimbal-mounted spot completes the Tonic family of high-CRI luminaires for retail.

Like all luminaires in Thorn's Tonic family, Tonic Gimbal is a truly global product supplied with a multi-voltage driver.

With a choice of single, double and triple frames, and interchangeable light heads including a range of spot and flood beams, Tonic Gimbal brings even more flexibility to the highly successful Tonic family.

Tonic Gimbal features lumen packages of 1800 lm or 2 800 lm, and an exceptional CRI of over 90, for vivid, true colour. Installation is simple, thanks to Thorn's unique "flag" system, which ensures a secure connection to the ceiling with no slipping.



A comprehensive family

With the introduction of Tonic Gyro and Tonic Gimbal, the Tonic family now represents a comprehensive range. Retail clients can now choose from a tool box of different configurations to create a consistent brand experience. For global brands, Tonic is a truly global spotlight. Worldwide availability and short delivery times ensure Tonic is easy to specify regardless of where your stores are.



As fast as fashion

Fashion moves fast, and lighting needs to respond just as quickly. The interchangeable lenses of Tonic Gyro and interchangeable light heads of Tonic Gimbal offer lighting designers unprecedented flexibility. Beams ranging from a tight 15° to a very wide 60° are available, while light heads of Gyro can rotate 355° and tilt 75°, Gimbal light heads are tiltable up to 30°. Tonic makes retail lighting design easy and fully adaptable.



Stunning colour

Thorn's Tonic luminaires boast a CRI of over 90, indicating an outstanding high colour rendering. But while some light sources favour warm hues at the expense of bright whites – or vice versa – Tonic's LED light source has been fine-tuned to combine pure, clean whites with intense, saturated colours. Whatever's in fashion, with Tonic, it will look its best.

Product specification

Application	Shop, retail and showrooms
Shape	Square (single/double/triple)
Lumen Output	1800 lm and 2 800 lm
Efficacy	Up to 90 lm/W
CRI	>90 vital white spectrum
SDCM	3
CCTs	3 000 K and 4 000 K (3 500 K on request)
Functionality	355° rotatable and 30° tiltable (gimbal) 355° rotatable and 75° tiltable (gyro)
Beam angles	SP/FL/WFL/VFL
Controls	Switchable

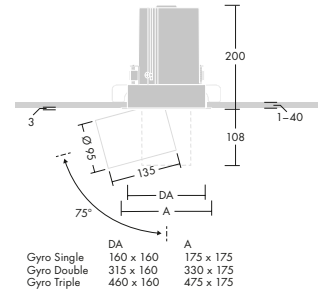

Design
Unobtrusive design.

Materials/Finish
Housing: aluminium, white RAL 9016 or black RAL 9005.

Colour rendering
Available in white and black.

To specify state:
Recessed luminaires with high flexibility for accent illumination. Excellent light distribution based on a lens reflector combination. LED light source 3 000 K and 4 000 K colour temperature, CRI>90 and a lifetime of 50 000 h L80. Available in white and black with passive cooling.

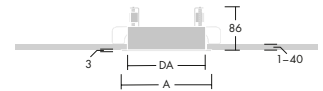
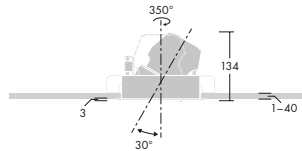

	DA	A
Gimbal Single	160 x 160	175 x 175
Gimbal Double	315 x 160	330 x 175
Gimbal Triple	460 x 160	475 x 175

Standards

As Thorn Tonic Gimbal and Gyro.

Tonic LED2800 SP

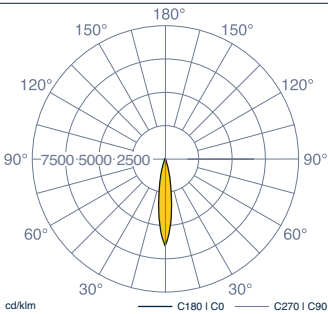

Tonic LED2800 FL

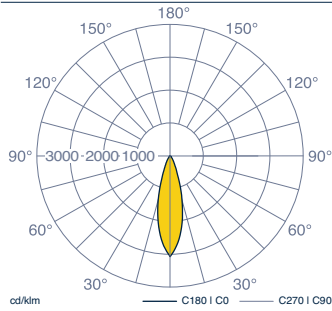

Tonic LED2800 WFL

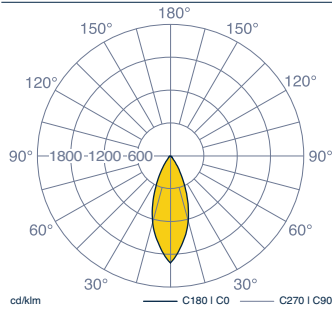

Tonic LED2800 VFL

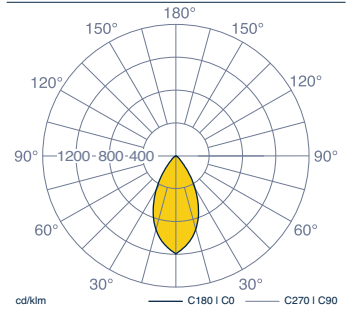

5 Year Warranty
As a globally leading luminaire manufacturer, Thorn Lighting provides a five-year warranty for its complete product range within all European Countries.

www.thornlighting.com/warranty

Thorn Lighting is constantly developing and improving its products. All descriptions, illustrations, drawings and specifications in this publication present only general particulars and shall not form part of any contract. The right is reserved to change specifications without prior notification or public announcement. All goods supplied by the company are supplied subject to the company's General Conditions of Sale, a copy of which is available on request. All measurements are in millimetres and weights in kilograms unless otherwise stated.

Publication No: 96644291 (INT) Publication Date: 11/17



www.pefc.org PEFC/6-38-214

THORN

