

FOSSÉS à PROJECTEURS



● Fosses CL21

Ground recessed boxes type CL21

- Cuve en fibre-ciment 10mm.
- **Couverture par verre :**
Dalle de 2 verres trempés SECURIT 10mm ;
Cadre inox 304L brossé ;
Joint d'appui EPDM.
- Fermeture vis CHC INOX A4.
- Support réglable du projecteur.
- Indice IK : 09
- Charge utile : 500kg
- Option : Sablage antidérapant.
- Poids : 44kg
- Fiber concrete housing: 10mm.
- **Glass enclosure:**
Double 10mm tempered SECURIT glass;
Brushed stainless steel frame: 304L;
Gasket: EPDM.
- Stainless steel screws.
- Adjustable floodlight support.
- IK rating : 09
- Static load : 500kg
- Optional : Sand blasted glass.
- Weight: 22kg

● Fosses CL01

Ground recessed boxes type CL01

- **Grille galvanisée à chaud :**
Barreaux de section 30 x 3 mm ;
Espace entre barreaux : 53 mm.
- **Charge utile : 500 Kg**
- **Galvanized steel grid:**
Bars 30 x 3 mm ;
Bars spacing: 53 mm.
- **Static load: 500 Kg**

Dimensions int. (cm) : 65 x 53 h 47

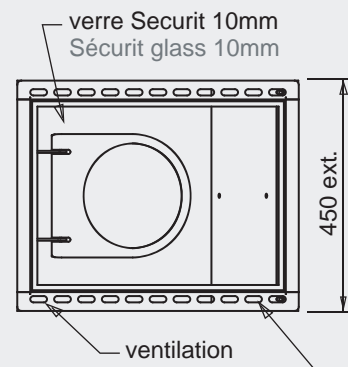
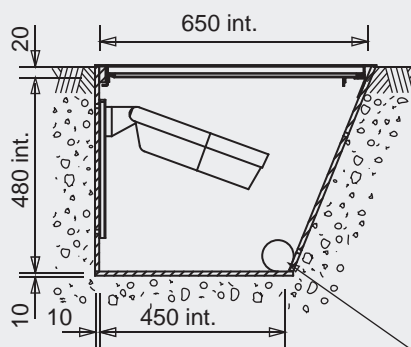
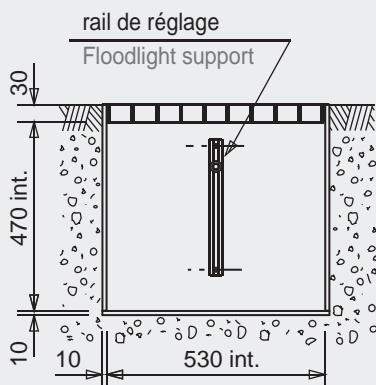

2 ouvertures Ø 70 pour câble et évacuation d'eau
2x Ø70 holes for power supply & drainage

cadre inox brossé
brushed stainless steel frame

Prévoir un système de drainage efficace raccordé sur un réseau si nécessaire.
Use an efficient drainage system installation if necessary.