

Technical Information

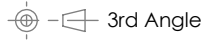

Design

Standard: BSEN 40

Finish

Galvanised to BSEN 1461:2009

Welding

In accordance with BSEN1011  
Procedures to BSEN ISO 15614-1:2017  
Welders Qualified to BSEN ISO 9606-1:2017

Approx. Weight: 3.73 kg

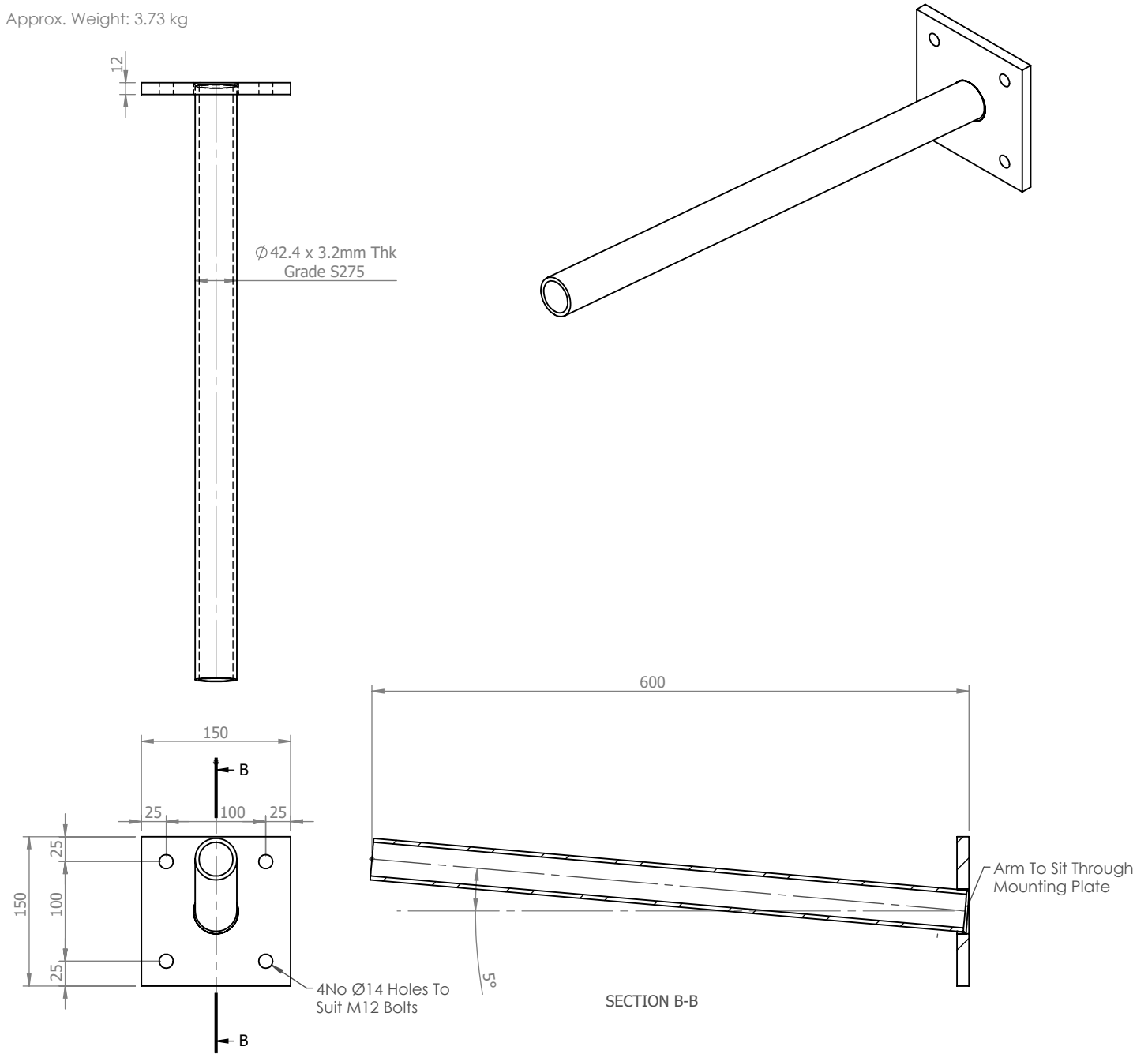

# THORN

Notes

All dimensions in millimetres unless stated otherwise.

When Multiple views are shown 3rd Angle Projection is assumed.

Title

0.5M Projection Wall Bracket

**96632784**

Drg No. 41730-3

Scale:1:6

Sheet 1 of 1