

Technical Information

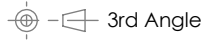

Design

Standard: BSEN 40

Finish

Galvanised to BSEN 1461:2009

Welding

In accordance with BSEN1011  
Procedures to BSEN ISO 15614-1:2017  
Welders Qualified to BSEN ISO 9606-1:2017

Approx. Weight: 2.4kg

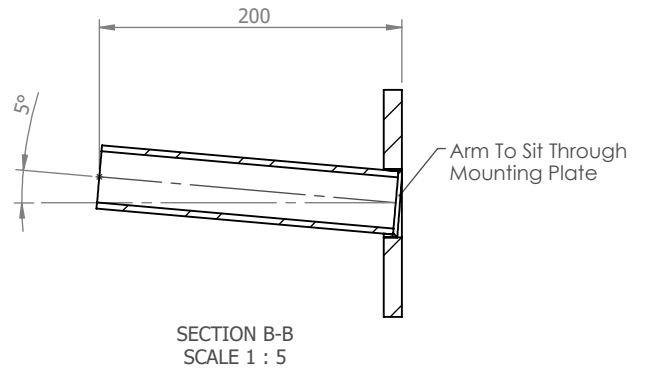
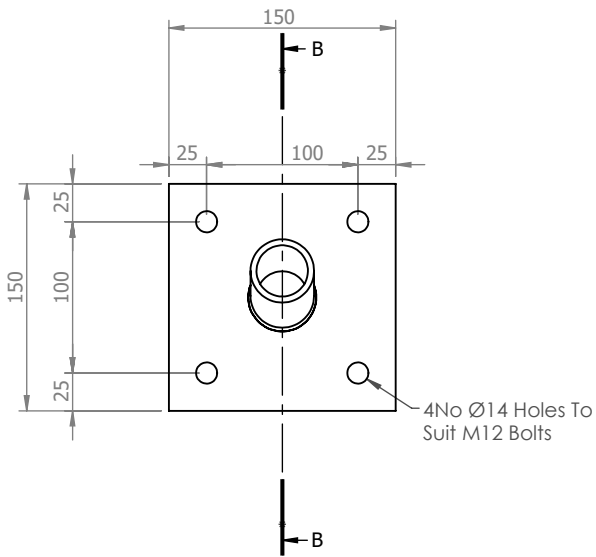
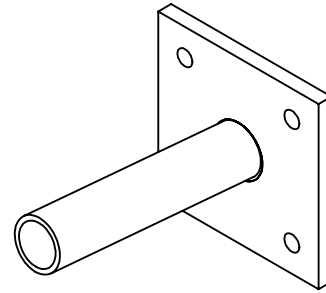
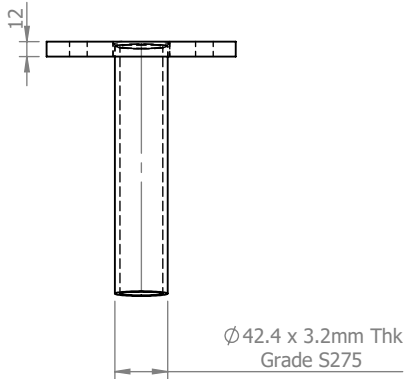

# THORN

**Notes**  
All dimensions in millimetres unless stated otherwise.  
When Multiple views are shown 3rd Angle Projection is assumed.

**Title**  
0.1M Projection Wall Bracket

**96632783**

**Drg No. 42336-2**

Scale:1:5  
Sheet 1 of 1