

Technical Information

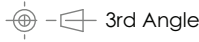

Design

BSEN40, PD6547: 2004+A1: 2009 (No Sign)
 Load Class B
 Deflection Class 3

Head load - See Table

Finish

Galvanised to BSEN 1461:2022

Welding

In accordance with BSEN1011
 Procedures to BSEN ISO 15614-1:2017
 Welders qualified to BSEN ISO 9606-1:2017

* Maximum design head load based on wind loading region with orientation of bracket/luminaire(s) being on the same plane as door

Approximate Column Weight: 52kg

96632706

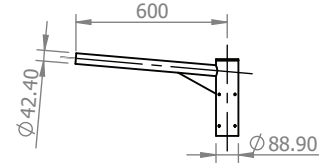
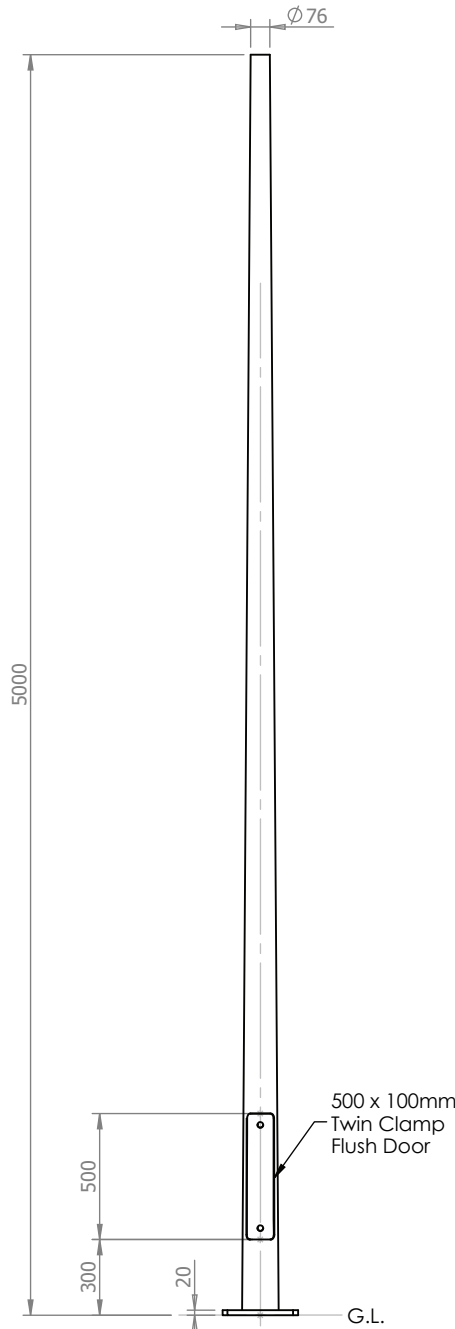

96632716 - Single Arm Bracket
 Approx Weight: 5.23kg

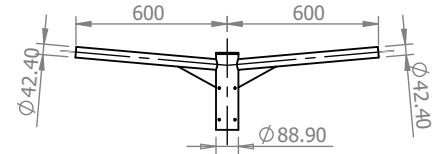

96632717 - Twin Arm Bracket
 Approx Weight: 7.36kg

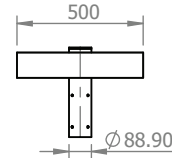

96632720 - Single Flood Light Bracket
 Approx Weight: 6.22kg

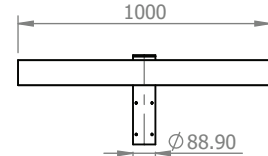

96632721 - Double/Quad Flood Light Bracket
 Approx Weight: 9.62kg

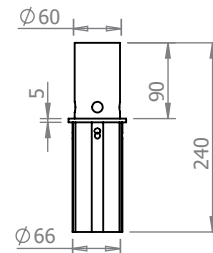

96633562 - 60mm Post Top Adaptor
 Approx Weight: 1kg

Maximum Loading Including Bracket		
Wind Loading Region	Terrain Category	Weight/Area
Extra Light	II	140kg/0.96m ²
	III	150kg/1.17m ²
Light	II	120kg/0.85m ²
	III	130kg/1.04m ²
Medium	II	100kg/0.80m ²
	III	110kg/0.95m ²
Heavy	II	80kg/0.75m ²
	III	90kg/0.90m ²
Extra Heavy	II	70kg/0.59m ²
	III	80kg/0.71m ²

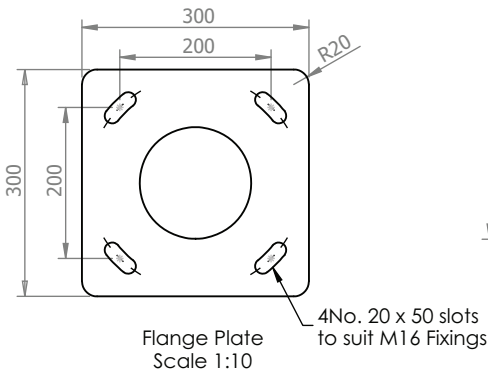

THORN
 LIGHTING

Title

5 Metre Tapered/Conical Flange Plated Post Top Column

Drg No. 49374-0

Scale:1:30
 Sheet 1 of 1

Notes

All dimensions in millimetres unless stated otherwise.

When Multiple views are shown 3rd Angle Projection is assumed.